

HAMMERTON

Hardware Packet "A"

For ceiling mount fixtures weighing 50–500lbs.

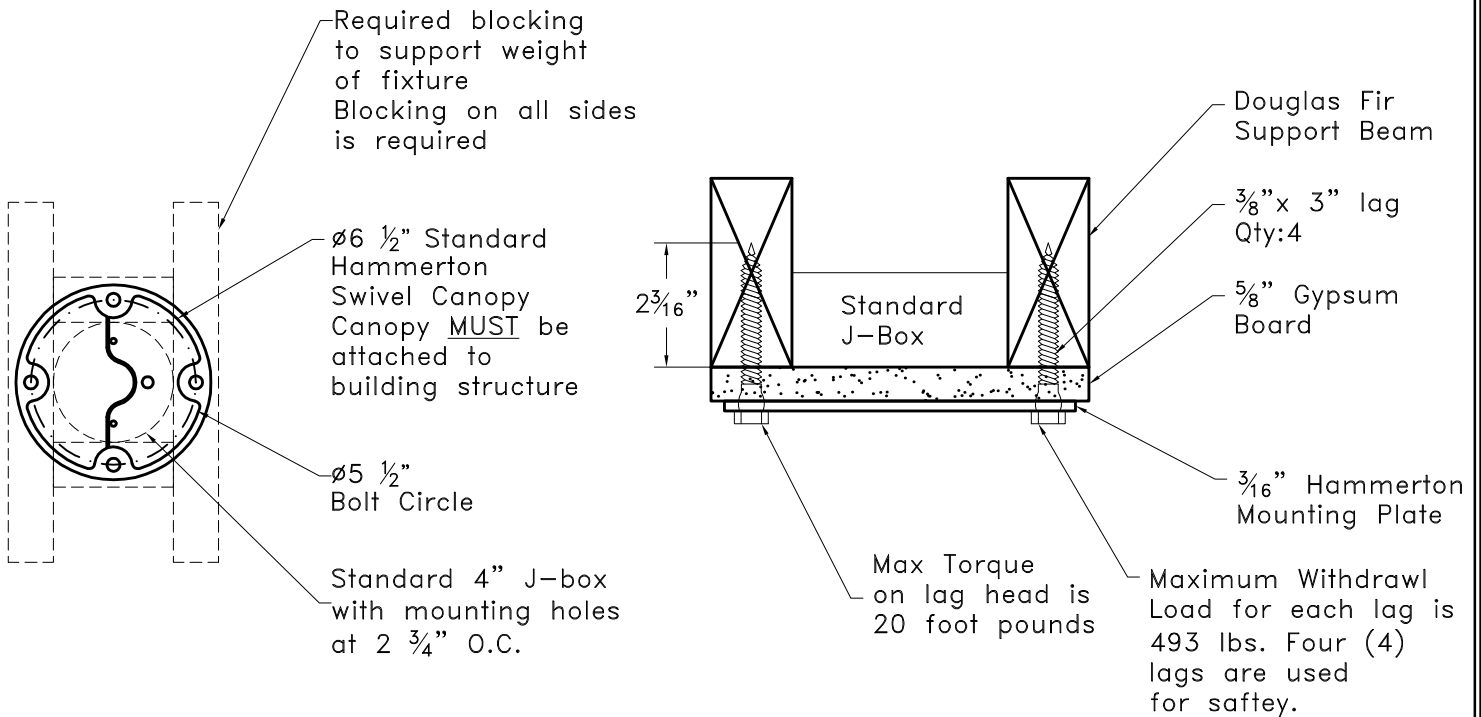

WARNING

It is the responsibility of the homeowner and general contractor to ensure that the provided canopy and hardware are installed correctly and that the supporting structure is capable of bearing the weight of the fixture.

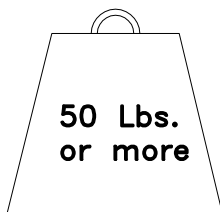

Scaffolding or a mechanical lift

should be available to assist in the installation of a fixture when the ceiling height exceeds 10'. Additional help and equipment may also be required when lifting the fixture into place.

The formula and equation shows the calculations used to determine mounting specifications for products manufactured by Hammerton.

Formula: $P=2840G^2DL$

Where: P= Maximum withdrawal load (lbs.)
G= Specific gravity of wood
D= Shank diameter of screw
L= Length of thread penetration

Formula and table were obtained from Fastenal Company Lab.

Example Equation for 3/8" Lag

$$P=2840(.46)^2 (.375)(2\frac{3}{16})$$

$$P= 492.96 \text{ lbs.}$$

$$492.96\text{bs.} \times 4 \text{ lags}=1971.85\text{lbs}$$

$$1972\text{lbs}/4(\text{safety factor})=493\text{lbs.}$$